

BESPOKE



MEASUREMENT GUIDE

A4/ INTERNATIONAL FORMAT



## GET STARTED

You will need a printer & scanner, A4 paper, a credit card, a flexible measuring tape as well as a thin pencil or pen. You need to calibrate your printer in order to print the guide correctly.

In the print settings select:

Resizing Options: Do not scale/ print actual size

Paper Options: A4 (210 mm x 297 mm)

Once the settings are set you can print this page 2 and perform a calibration check.

If the calibration is ok you can print pages 3-5 and do the calibration check again for each page.

## START MEASURING

Follow our detailed measuring instructions on page 3 to measure your feet correctly. As a quick proxy, whether you took your measurements correctly, compare your measured foot length to your usual shoe size via the size conversion chart below (if your shoe size is bigger or smaller than the sizes outlined in our chart, please contact us before purchasing) If the measurements are off, please contact us and we will find the right solution for you!

## SIZE CONVERSION CHART

Our below size conversion chart can help you convert your shoe size between European, British, American, and Japanese to determine whether you measured correctly.

European	39	39.5	40	40.5	41	41.5	42	42.5	43	43.5	44	44.5	45	45.5	46	46.5	47
British	5	5.5	6	6.5	7	7.5	8	8.5	9	9.5	10	10.5	11	11.5	12	12.5	13
American	6	6.5	7	7.5	8	8.5	9	9.5	10	10.5	11	11.5	12	12.5	13	13.5	14
Japanese	240	245	250	255	260	265	270	275	280	285	290	295	300	305	310	315	320
cm	25.2	25.5	25.8	26.2	26.5	26.8	27.2	27.5	27.8	28.2	28.5	28.8	29.2	29.5	29.8	30.2	30.5
inches	9.9	10.0	10.2	10.3	10.4	10.6	10.7	10.8	11.0	11.1	11.2	11.4	11.5	11.6	11.7	11.9	12.0

### CALIBRATION CHECK

This area should have identical dimensions as a regular credit card if the PDF has been Printed correctly.

## BESPOKE

1. Make sure to measure both feet, as no foot is like the other and might need varying last adjustments.

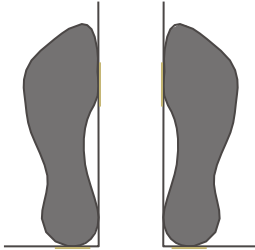

### ADVICE

During the day your shoe size can sometimes differ because feet can swell up. It is possible that you will have a different size in the morning than in the evening. Please measure your feet in the afternoon, when your feet are at their biggest.

Socks of different thicknesses can influence the result. Please put on a pair of socks that you will also wear with your new shoes.

2. **IMPORTANT: Stand up** and place your foot on the measurement template.

Please note, that your **heel should be seated exactly on the logo with the back of your heel touching the dotted line**, while your **foot's inner side should precisely follow and touch the vertical line**.

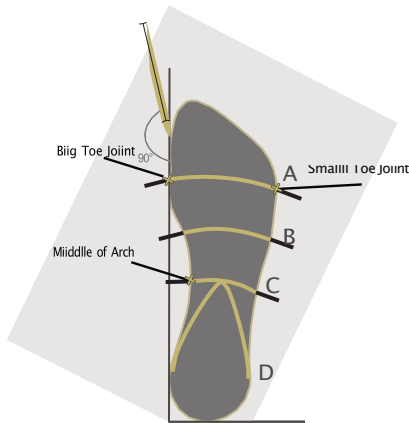

3. Have another person draw the outline of your feet. Use a sharp and thin pen or pencil and try holding it **orthogonal to the floor and as close to your foot as possible**.

4. **Mark the position and angle of your tape measure for each measurement on the paper (like the black markings in the demonstration on the left side).**

**IMPORTANT: Pull the tape measure as tightly/ snug as you want your semi-bespoke shoes to fit.**

**A** = Wrap the tape measure around the widest part of your toes from the big toe joint to the bulge at the side of the little toe.

**B** = An extra measurement which should be taken exactly in between measurements A and C.

**C** = Wrap the tape around the narrowest possible route from the middle of the arch to a point approximately 2cm above the centre of the instep bone (There is usually a bump at this point which should be felt before measuring).

**D** = Place the beginning of the tape measure on the point just above the centre of the instep bone (as in C) and wrap it around the back of the heel where it touches the ground and finish at the start point just above the centre of the instep bone.

### 5. Additional Measurements for Boots

**E** = The Height measurement is taken on the outside of the leg from the ground to where the ankle measurement will be taken in step F.

**F** = The Ankle measurement is taken around the narrowest part of the leg near the ankle.

6. **G: Foot Length** = Measure the length of your foot from where your heel starts to the tip of your longest toe along the measuring line.

**H: Forefoot Width** = Measure the width at the widest part of your forefoot.

**I: Heel Width** = Measure the width of your heel at its widest part.

7. Circle the areas where you usually have some kind of fit issues.

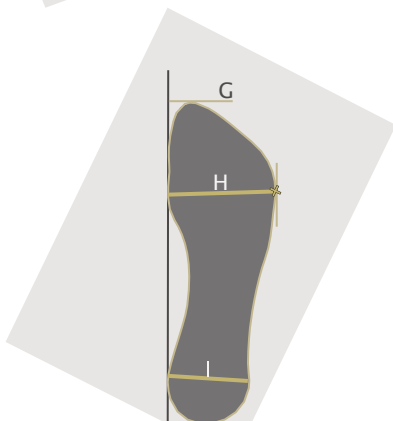
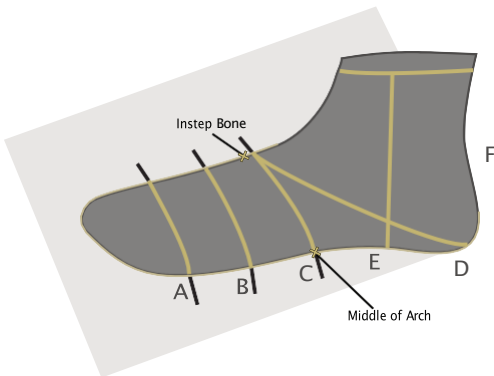

# RIGHT FOOT

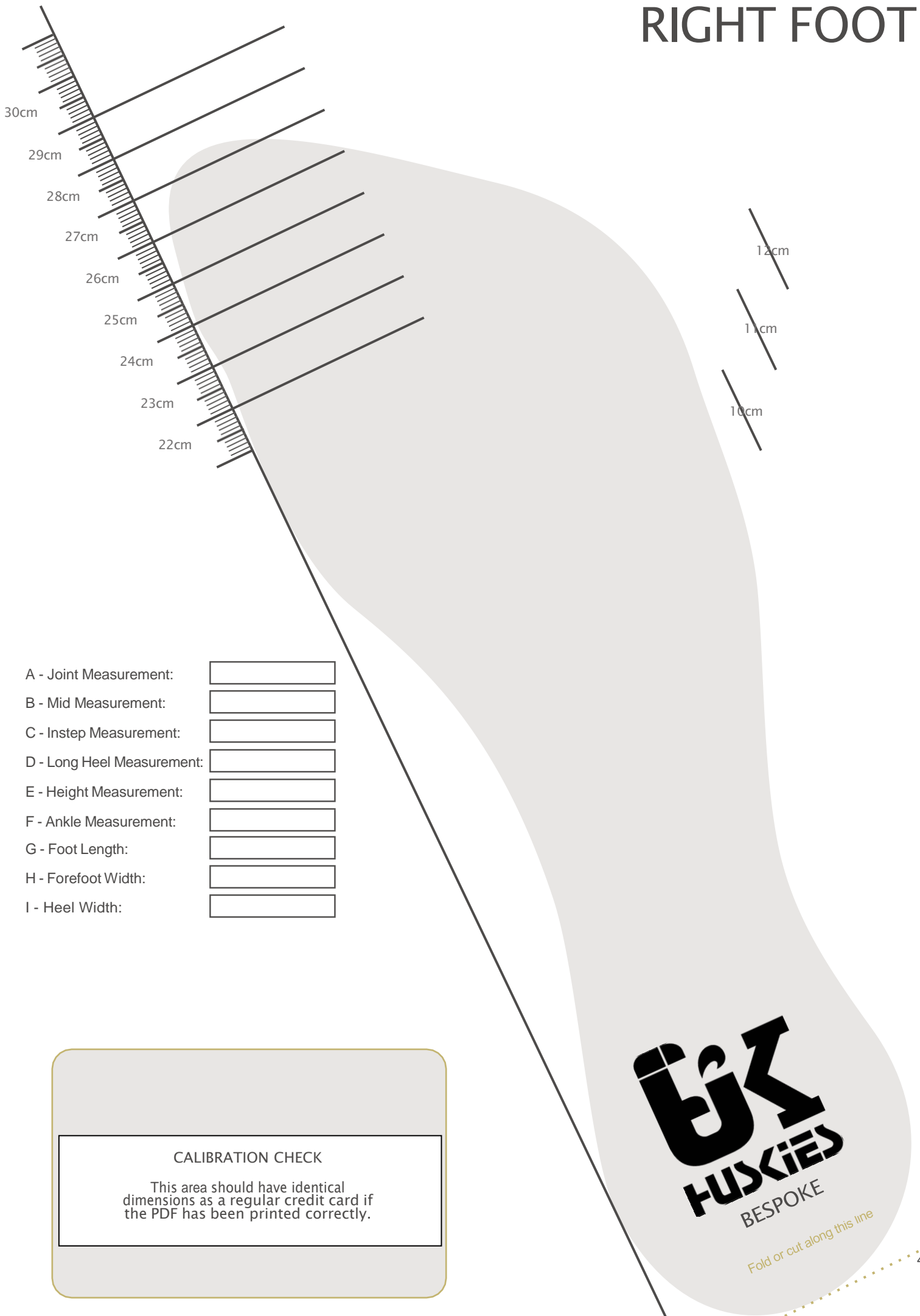

- A - Joint Measurement:
- B - Mid Measurement:
- C - Instep Measurement:
- D - Long Heel Measurement:
- E - Height Measurement:
- F - Ankle Measurement:
- G - Foot Length:
- H - Forefoot Width:
- I - Heel Width:

**CALIBRATION CHECK**

This area should have identical dimensions as a regular credit card if the PDF has been printed correctly.

**UK  
HUSKIES**  
BESPOKE

Fold or cut along this line

# LEFT FOOT

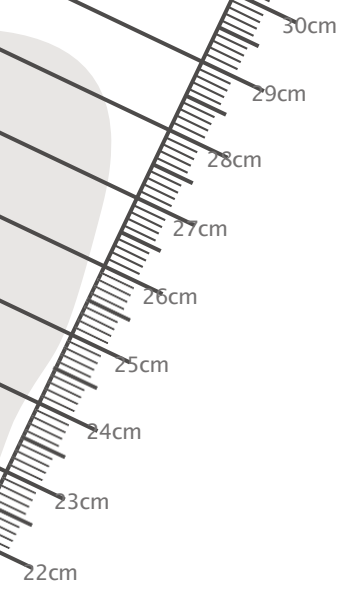
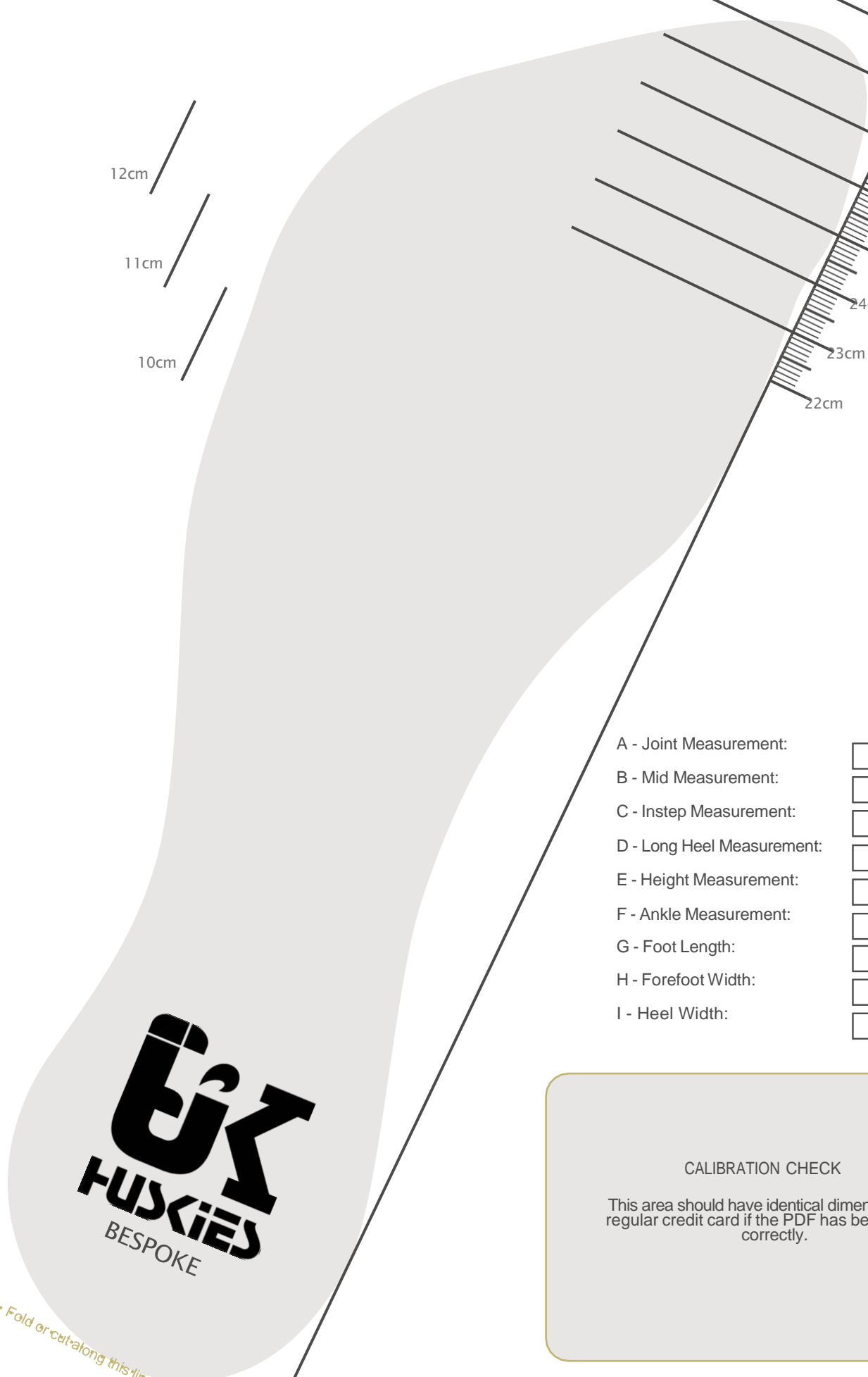
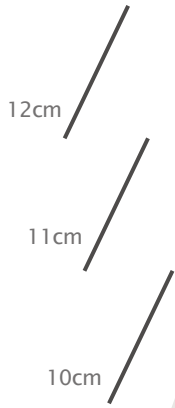

A - Joint Measurement:

B - Mid Measurement:

C - Instep Measurement:

D - Long Heel Measurement:

E - Height Measurement:

F - Ankle Measurement:

G - Foot Length:

H - Forefoot Width:

I - Heel Width:

**UK**  
**HUSKIES**  
BESPOKE

## CALIBRATION CHECK

This area should have identical dimensions as a regular credit card if the PDF has been printed correctly.

Fold or cut along this line